

ROLL TRAC®

For Effective and Economical Space Management Solutions



THE VERSATILE WAY TO PUT SPACE TO WORK FOR YOU

ROLL TRAC is ideal for:

- Power Wash Stations
- Protection against airborne particles or environmental hazard
- Helping to eliminate heat or cooling losses
- Restricting visibility for privacy
- Energy and fuel conservation
- Safety precautions

ROLLTRAC Moving Curtain Partitions from Mauritzon Inc. offer a fast, easy and cost-effective method to manage the work environment by creating specific areas or zones by means of curtains that simply roll back when not in use. There are a wide variety of curtain sizes, materials and hardware components to choose from to form booths and cubicles of any height or configuration. And they can be installed easily by your own maintenance personnel without special tools or skills.

Mauritzon ROLLTRAC is designed for industrial, commercial and institutional use. It is functional yet attractive, durable and strong, with all components protected against rust and corrosion to ensure long life and smooth, effortless rolling, time after time.

CHOOSE FROM 6 SUSPENSION TECHNIQUES

Before ordering your RollTrac System, determine the precise area to be enclosed, the number of sides and dividing panels needed and the height of the curtain or curtains required. You will want to consider the possibility of rounded corners which may be traversed by the curtain, or curtain-stopping right angles. Check the 6 suspension techniques that follow and determine which best suits your requirements. Then order the appropriate hardware parts. Note: utilize at least 1 support connector for each 5 feet of RollTrac. Available curtain materials are described on page 66. When measuring the width of curtains, add 10% for draping

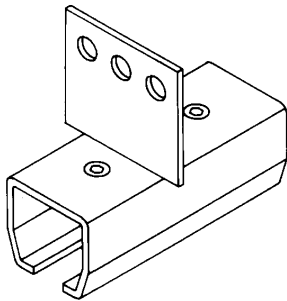

BEAM OR CHAIN SUPPORTMOUNT

Attaches to beam or any member immediately above the top level of the curtain. May be used with round or right angle corners.

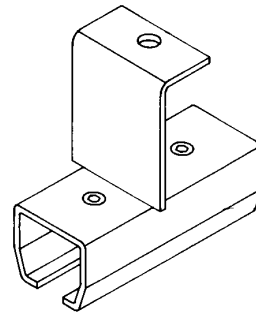

THREADED ROD

For use when there are no easily accessible structures near the track. Threaded Rod attaches to the ceiling height significantly above the track system.

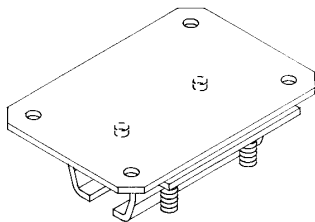

CEILING MOUNT

Attaches directly to ceiling or any flat horizontal surface directly above the curtain. May be used with round or right angle corners.

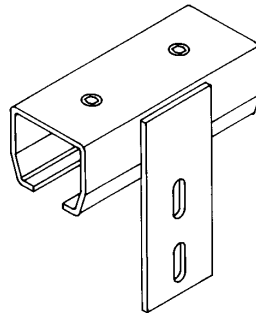

WALL MOUNT

Attaches to walls or any vertical surface. May be used with other mounting techniques.

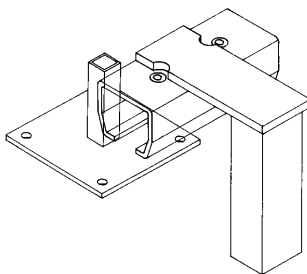

FLOOR COLUMN (Free Standing)

Permits erection of screens in any area. Base and tube assembly may be used with round or right angle corners.

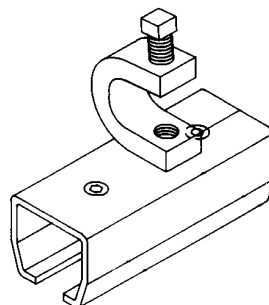

BEAM FLANGE

Permits attachment of roof truss section, beams and channels. Secured with edge clamps and set screws. Clamps can be rotated for proper alignment.

ROLLER TRACK

*AVAILABLE IN STAINLESS STEEL

16 gauge galvanized steel Roller Track up to 20 ft. long. Holes for connectors punched in the ends.

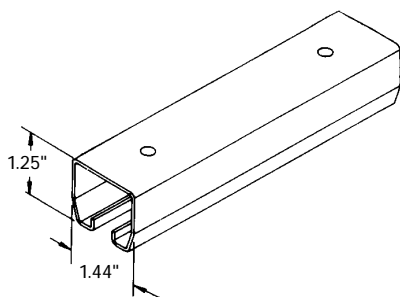

Length	Product Number
2 Ft.	7710K10
4 Ft.	7710K11
5 Ft.	7710K12
6 Ft.	7710K13
7 Ft.	7710K14
8 Ft.	7710K15
9 Ft.	7710K16
10 Ft.*	7710K17
12 Ft.	7710K18
14 Ft.	7710K19
16 Ft.	7710K20
20 Ft.	7710K21

*Also available in 12 gauge steel and Stainless Steel

FOB Chicago, IL

Special Volume Pricing

PLAIN CURVED TRACK



24" Radius Curved Track with Plain Connectors
7710K25*

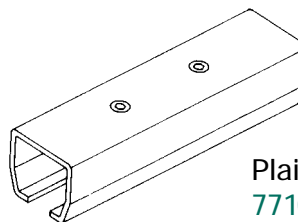

Plain Connector
7710K38*

FOB Chicago, IL

Special Volume Pricing

TRACK END STOPS

FOB Chicago, IL

Special Volume Pricing

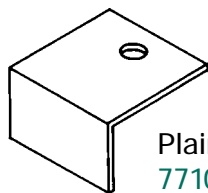

Plain End Stop
7710K31*

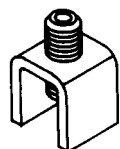

Adjustable End Stop
7710K31-A*

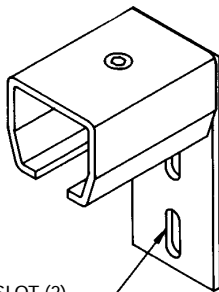

.25" x .75" SLOT (2)

Wall Mount End Stop Flange Down
7710K32*

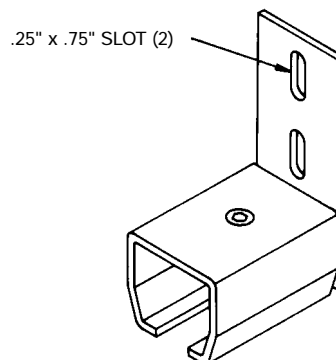

.25" x .75" SLOT (2)

Wall Mount End Stop Flange Up
7710K33*

BEAM OR CHAIN SUPPORT MOUNT

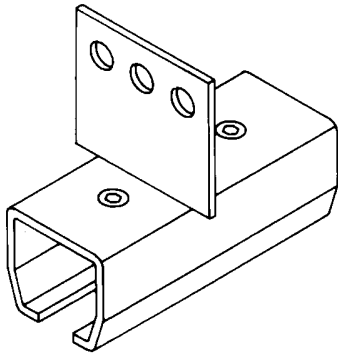

Attaches to beam or any member immediately above the top level of the curtain. May be used with round or right angle corners.

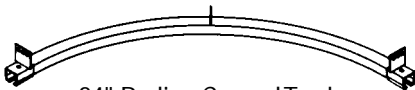

24" Radius Curved Track with Three Supports
7710K24*

SUPPORT HARDWARE

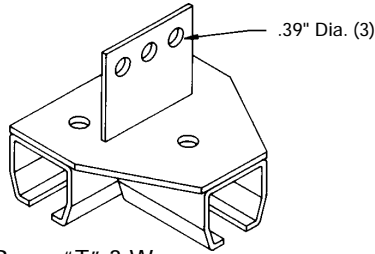

Beam "T" 3-Way Connector
7710K65

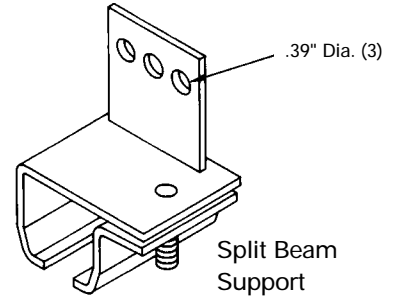

Split Beam Support
7710K36-A*

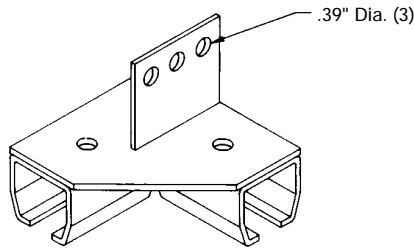

90° Beam Support Angle Connector
7710K61*

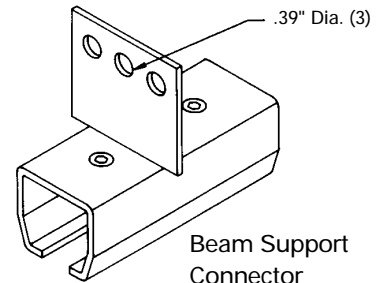

Beam Support Connector
7710K36*

*Available in 12 gauge steel & stainless steel

FOB Chicago, IL

Special Volume Pricing

CEILING MOUNT

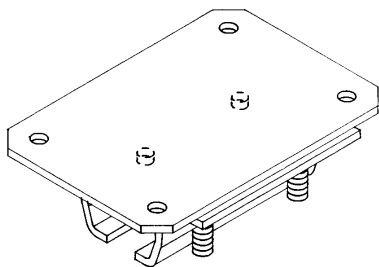

Attaches directly to ceiling or any flat horizontal surface directly above the curtain. May be used with round or right angle corners.

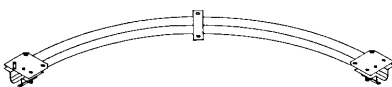

Curved Track with Three Ceiling Supports
7710K26*

SUPPORT HARDWARE

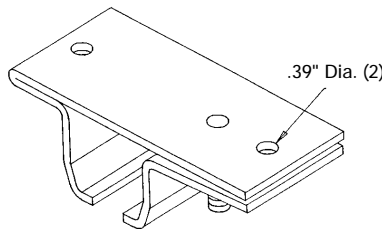

Ceiling Support Split
7710K37-A*

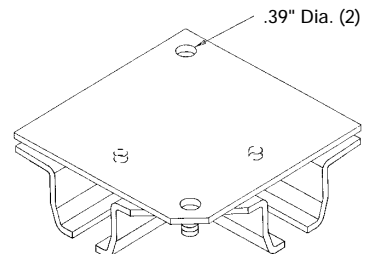

90° Ceiling Angle Connector
7710K62

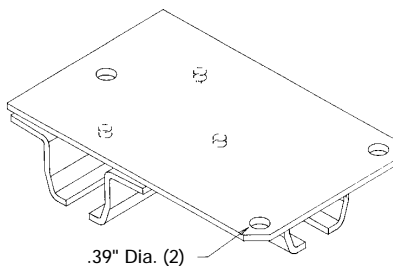

Ceiling "T" 3-Way Connector
7710K63

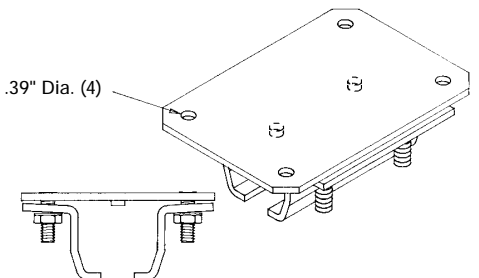

Ceiling Support Connector
7710K37*

*Available in 12 gauge steel & stainless steel

FOB Chicago, IL

Special Volume Pricing

FLOOR COLUMN (Free Standing)

SUPPORT HARDWARE

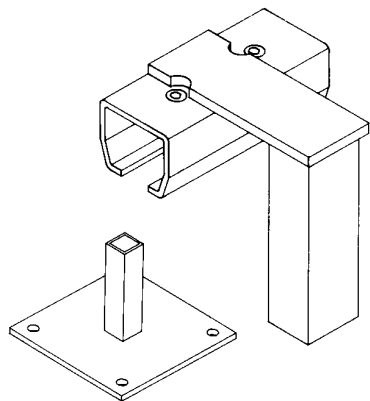

Floor "T"
Bracket
3-Way
Connector
7710K53

Floor Mount
Columns
6' - 7710K76
7' - 7710K77
8' - 7710K78

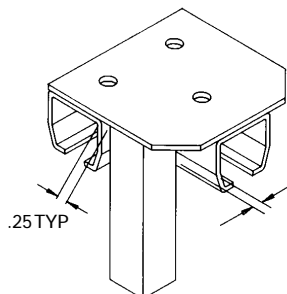

90° Angle
Connector
Floor Mount
7710K52

Floor Mount
Track
Bracket
7710K55-A

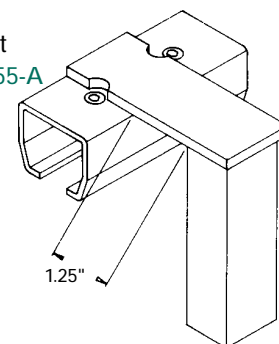

Permits erection of curtains in any area. Base and tube assembly may be used with round or right angle corners.

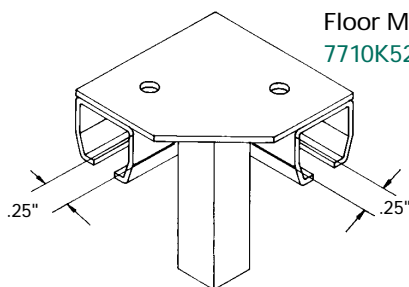

Split
Support
Floor
Mount
7710K55

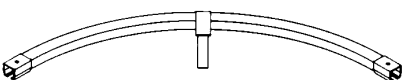

Floor Mount Curved Track
24" Radius
7710K56

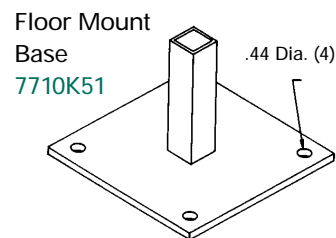

Floor Mount
Base
7710K51

FOB Chicago, IL

Special Volume Pricing

FOB Chicago, IL

Special Volume Pricing

THREADED ROD

SUPPORT HARDWARE

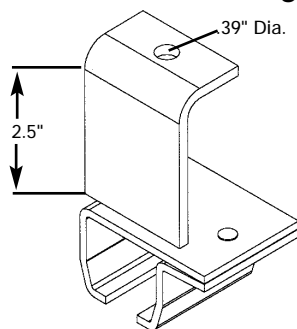
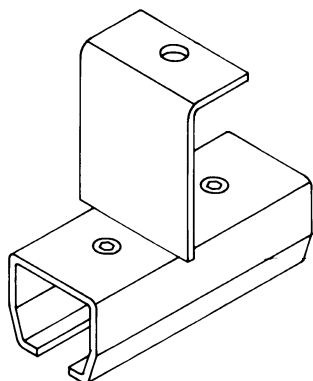

Threaded
Rod
Split
Support
7710K84

"T" Bracket
3-Way
Connector
7710K86

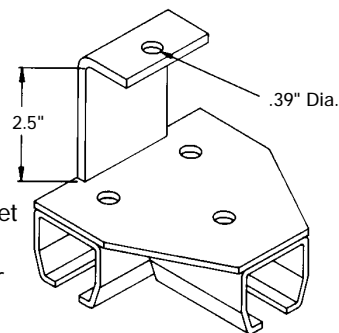

Threaded
Rod
Connector
7710K83*

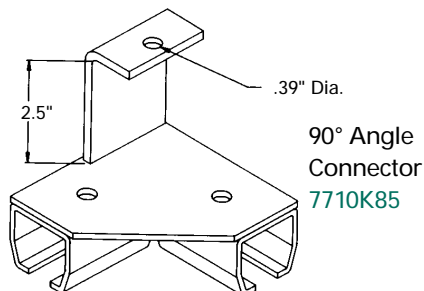

90° Angle
Connector
7710K85

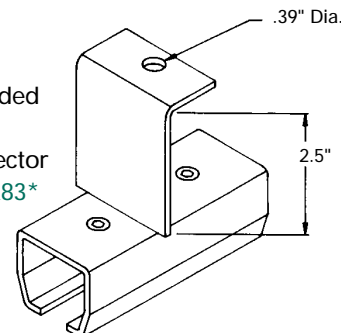

For use when there are no easily accessible structures near the track. Threaded Rod attaches to the ceiling height significantly above the track system.

WALL MOUNT

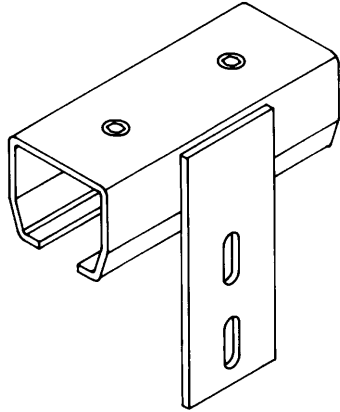

Attaches to walls or any vertical surface. May be used with other mounting techniques.

FOB Chicago, IL

Special Volume Pricing

FOB Chicago, IL

Special Volume Pricing

SUPPORT HARDWARE

Wall Mount Bracket Flange Up
7710K47

.25" x .75"
SLOT (2)

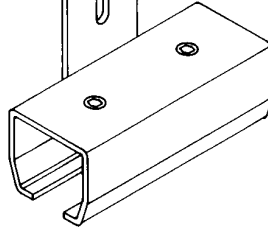

Wall Mount Bracket Flange Down
7710K46*

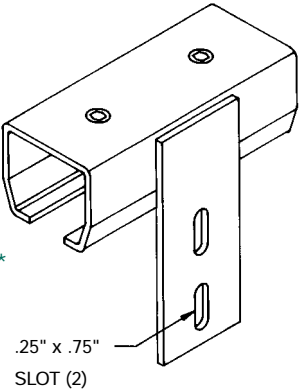

.25" x .75"
SLOT (2)

Split Support Bracket Flange Up
7710K47-A*

.25" x .75"
SLOT (2)

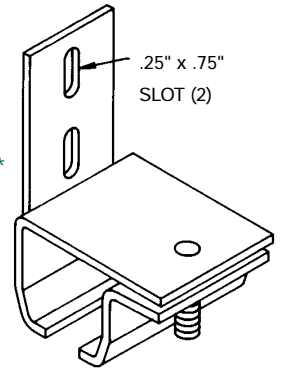

Split Support Bracket Flange Down
7710K46-A

.25" x .75"
SLOT (2)

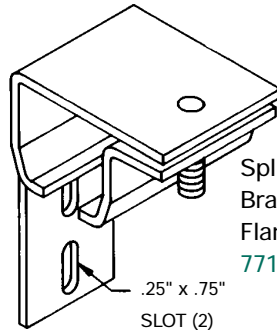

BEAM FLANGE

SUPPORT HARDWARE

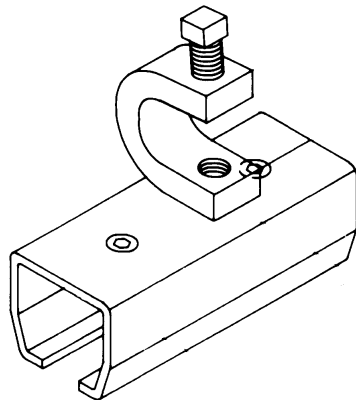

Permits attachment of roof truss section, beams and channels. Secured with edge clamps and set screws. Clamps can be rotated for proper alignment.

Beam Flange Connector
7710K87

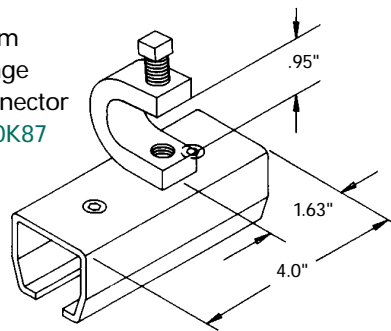

Beam Flange Split Support
7710K88

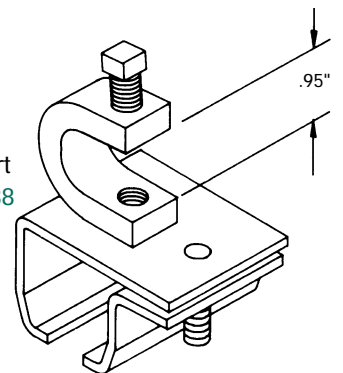

Beam Flange 90° Angle Connector
7710K89

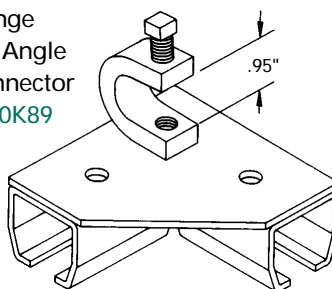

Beam Flange "T" 3-Way Connector
7710K90

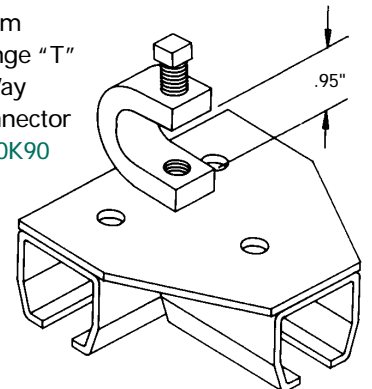

CURTAIN TROLLEYS

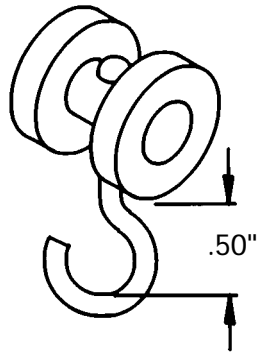

Nylon Roller
with 1/2"
Hook
7710K41

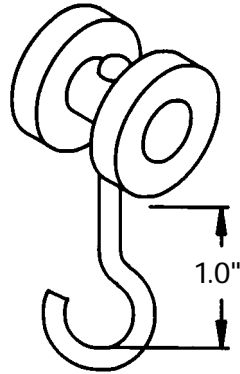

Nylon
Roller
with 1"
Hook
7710K42*

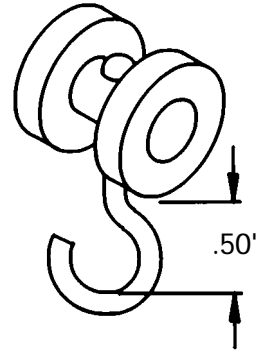

Steel Ball
Bearing
Roller
with 1/2"
Hook
7710K43*

FOB Chicago, IL

Special Volume Pricing

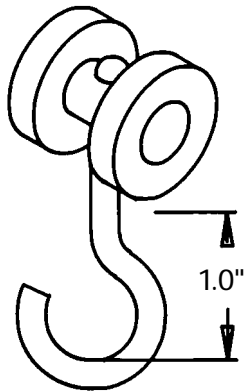

Steel Ball
Bearing
Roller
with 1"
Hook
7710K44*

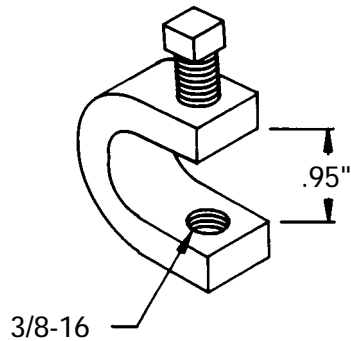

Edge
Clamp
7710K91

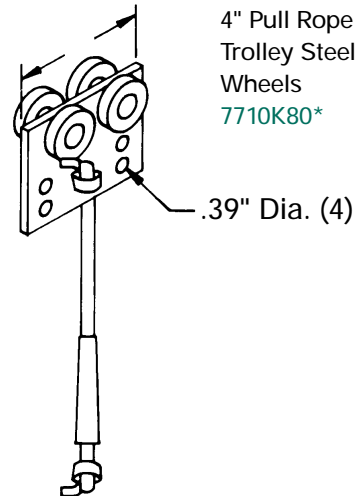

4" Pull Rope
Trolley Steel
Wheels
7710K80*

FOB Chicago, IL

Special Volume Pricing

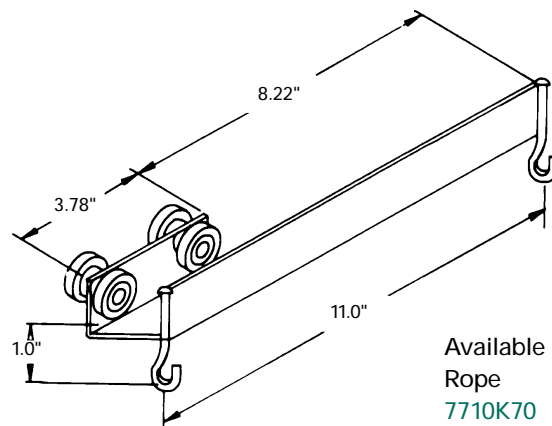

Overlap Trolley
Steel Wheels
7710K72*

Available with Pull
Rope
7710K70

FOB Chicago, IL

Special Volume Pricing

MISC. SUPPORT COMPONENTS FOR MOVABLE CURTAINS

ENCLOSED TRACK CAPACITY AND DEFLECTION

The charts below illustrate track capacity for various support spacings. The curves represent loads evenly distributed between supports (left) and loads concentrated at the center of the span (right). Interpolate between these two curves when the total load can be bunched together and is not long enough to fill the space between the supports.

Curves on the chart represent the track loaded at 15,000 psi maximum stress. Since yield stress for the low carbon steel track is 30,000 psi, the factor of safety at these loads is 2:1. The factor of safety compared to ultimate tensile strength is 3:1.

For hazardous applications where these factors of safety are inadequate, multiply the actual loads by compensating factors before using the charts. High elevation above the floor or the presence of a catwalk or other maintenance area near the track system might qualify for a more conservative design.

16RT LOAD DEFLECTION CHART LOAD EVENLY DISTRIBUTED BETWEEN SUPPORTS

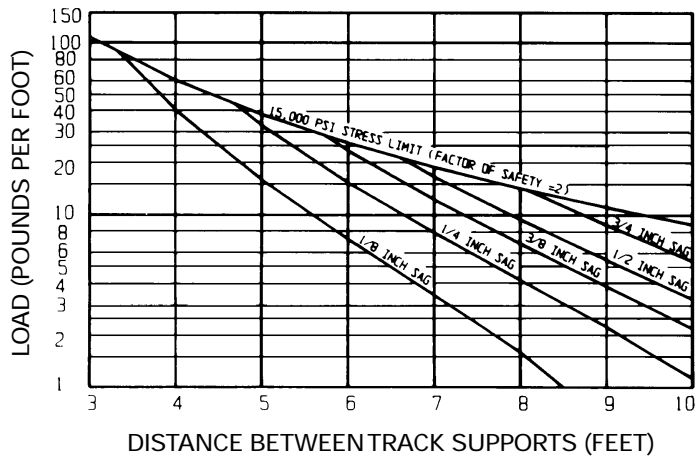

16RT LOAD DEFLECTION CHART ENTIRE LOAD AT ONE POINT MIDWAY BETWEEN SUPPORTS

